

# GSM Lift Watch

## GSM LIFT COMMUNICATION SYSTEM



**Installation guide v1.0**



The GSM lift watch is designed for emergency call from lift cabin ( 1 or 2) to first aid ( service department, security, etc..). Setting as same as controlling is possible also remotely by SMS messages( control of lift status, lift reset etc...).

### **Basic technical parametres:**

Power supply	9 to 18VDC, 50 to 500mA (up operation) backup via acumulator
GSM network	900/1800MHz
Ext.signallization	LED or light 12V (24V) max.100mA
Relay contacts	2x 24V/100 mA
Basic unit	195 x 95 x 34 mm
ReMic modul	110 x 78 x 52 mm

### **Functionality:**

- After activation ( button push) progressively call up 8 numbers (MASTER1-8) saved on the SIM card with automatic call duration max. 4 minutes
- Back call only from MASTER numbers saved on SIM card. Another calls are refused.
- Credit information at prepaid SIM cards.  
Information is sent by SMS to selected number
- Indication of calling as same as connection
- Automatic verification call once for 3 days to TEST number(s) (TEST1-8) saved on the SIM card
- Command SMS mode for remote control (SMS might be sent only from TEST numbers):
  - Control of 2 relay contacts for lift reset
  - Status of the lift (5 inputs – 2 are blocking inputs)
  - MASTER and TEST numbers changing
  - Control of GSM network status  
Credit information
- 2 blocking inputs – emergency call available only during lift failure

- 2 blocking inputs might be used for sending SMS with info about lift failure (failure signal on input longer than 2 minutes)
- Sending of preprogrammed SMS when is lift failure – SMS is sending during change of input status longer than 2 minutes

## **Emergency call from lift cabin**

After button pressing the unit dial up progressively phone numbers saved as MASTER1 to MASTER8 on SIM card inserted in GSM modul. When call is succesful the rest of numbers are not dial. When call is hanged up the unit coming back to stand by mode. The operation is indicated by internal signalization. At the moment of activation is closed output of external signalization I1 (dialling the numbers). After picking up of call the output is open and the output I2 is closed (connection established).

## **Blocking of emergency call**

Activation might be blocked by short circuit of appropriate blocking input (Port4 – lift 1 and Port5 - lift 2). If Port4 (Port5) is short circuit against ground (lift is not failed) the button for emergency call is blocked. When Port4 (Port5) is open the blocking is cancel. Simultaneously (if Port4 (Port5) is open longer than 2 minutes is sending preprogrammed SMS message (lift failure) to preprogrammed number.

## **Back call**

The unit might be activated also by incoming call. It is possible only when you make a call from numbers MASTER1 to MASTER8 saved on SIM card. The call is connected always to lift cabin where was pressed button as last.

## **Remote lift reset**

The unit enables remote control of 2 independent relay contact via SMS (order RES1 and RES2). It useful for switching of reset inputs of the lift or other control (the relay contacts are closing for 5 seconds).

It is ensured that back call is going always to lift cabin where from came last call.

### **Testing (verification) call**

When are saved on the SIM card numbers under name TEST1 to TEST8 the unit automatically call on them once for 3 days. The unit behaviour is the same as when button is pressed but the call is performed to different group of numbers. (not MASTER but TEST). The phone numbers MASTER and TEST might be the same! The difference is when call is refused. When it is emergency call the unit dial next number in the order ( if call is not picked up or refused). When it is testing call the next number in order is dial if call is not picked up. When call is refused the unit not dial next number.

### **Credit status**

The unit control status of the SIM card credit when is used prepaid card. The unit send SMS to preprogrammed number with notification about low credit. \*

\* depends on GSM network

### **The lift status**

The data inputs (Port 1-5) are useful either for monitoring of the lift or for emergency call blocking (Port 4 Port5). The Port1 (close jumper on the PCB) is monitoring the status of powering (backup). The status all inputs (ports) is accessible remotely by SMS.

### **Remote control and setting**

All parametres might be control and setting by SMS remotely. The SMS are accepted only from numbers saved on the SIM under name TEST1 to TEST8.

## The parts of GSM lift Watch:

Basic unit



The speaker  
and microphone  
module (ReMic)

Setting of speaker loudness – lift 2

Setting microphone sensitivity – lift 2

Setting of speaker loudness – lift 1

Setting microphone sensitivity – lift 1

Indication of GSM operation (red LED)

Indication of powering GSM (green LED)



Screw terminal – lift 2

Screw terminal – lift 1

Indication of inputs status

Screw terminal - ports

The unit interface (PC setting, testing, connection of other systems etc... )

Screws for backup acumulator  
**USE WITH CHARGER ONLY!**

## Screw terminal PORT

5 inputs: open = 1  
close = 0



LED lighting when in = 0

Ground (gnd)

Input of 2. lift blocking  
(short circuit against gnd)

Input of 1. lift blocking  
(short circuit against gnd)

3 inputs for lift status  
monitoring

## Screw terminal LIFT1(2)

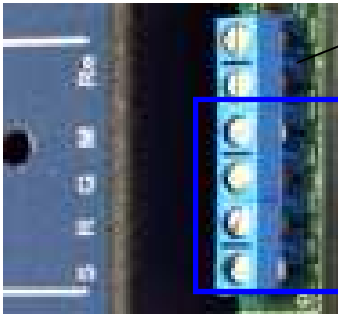

Screws relay contact

Screws for connection to  
ReMic modul instal in  
the lift cabin – connect  
together the same  
marked screws  
M – microphone  
G – ground  
R – loudspeaker  
S - signalization

## Screw terminal of ReMic modul



Screw of indicator I1

Screw of indicator I2

Screw for button - activation

Screw for connection to basic  
unit – connect together the same  
marked screws (via above)

Isolated screws – call activation  
by leading voltage 12V



## Installation:

- Fix the ReMic modul to back side of lift cabin. We recommend fix it in the head level for better sound. The microphone **The microphone must be free through lift cabin otherwise the sound from lift cabin will be wrong!**

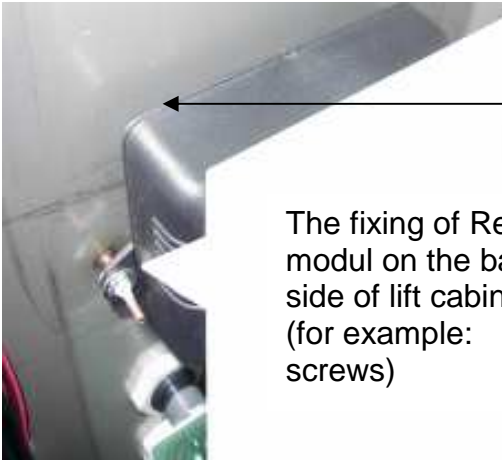

The loudspeaker and microphone are in direction into lift cabin

The fixing of ReMic modul on the back side of lift cabin (for example: screws)

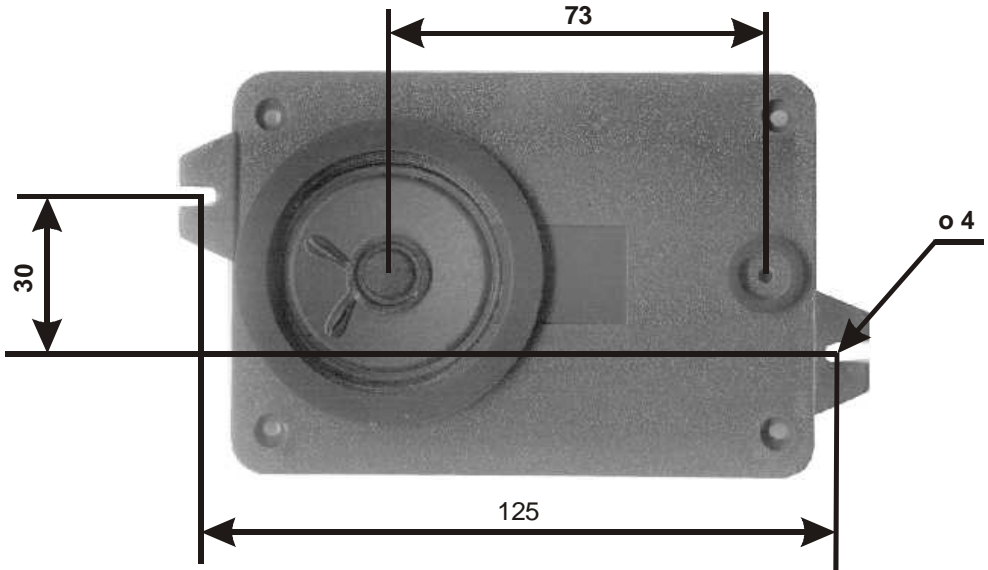

- Fix the basic unit either on lift cabin or in machine room (necessary when use it for 2 lift cabins). The GSM signal determine where basic unit is install. The installation on lift cabin is easier but you must verify that GSM signal is available during all lift way. Keep enough space for SIM card manipulation.

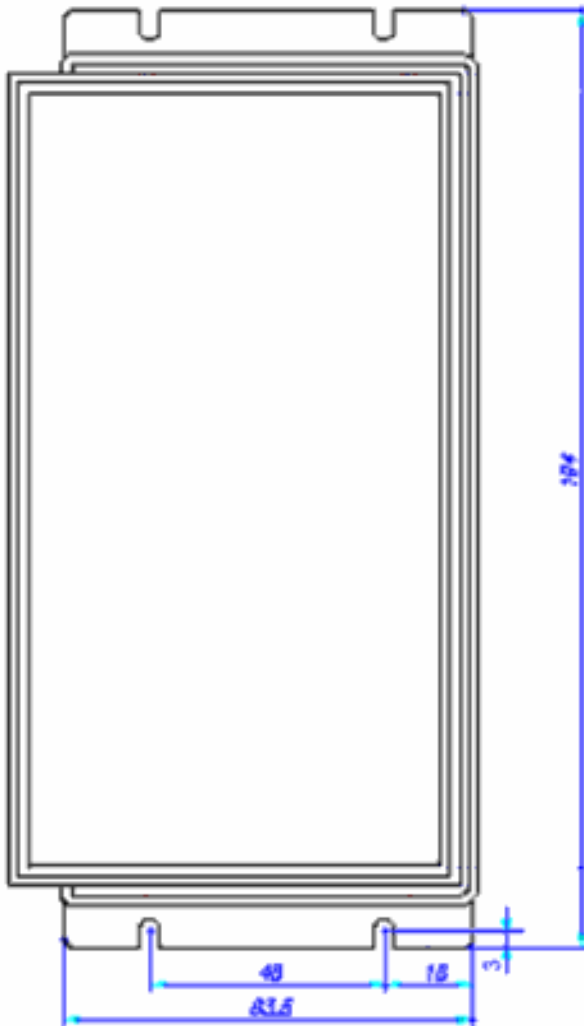

- Connect antenna via antenna connector. The antenna must not be placed inside cover space! It is necessary to provide good quality of GSM signal. The location of "magnetic" antenna is the best on bigger iron subject which enables to create bigger GSM signal power. It is also important to place antenna out of basic unit to not interference the voice channel by GSM radiation ( you know it from radio in car)
- Up drawing mentioned above connect ReMic modul to basic unit. To the ReMic modul connect indication And activation button. Do not connect power supply. At the basic unit do not connect inputs (port) yet.

## **The unit programming**

The basic unit might be programm by 3 ways:

1. By PC (RS 232) via unit interface.
2. By mobile phone where insert the SIM card.
3. Remotely by SMS messages. On the SIM card must be already preprogrammed min. MASTER 1 number.

## **General requirement on numbers and SMS messages saved on the SIM card**

CAUTION: The unit presume that on the SIM card are saved only information used for operation!!!

On the SIM card are saved all numbers and SMS which are used by unit. Called numbers after button pressing are saved under name MASTER1 to MASTER8, eventually TEST1 to TEST8. The number where is send SMS about credit info is saved together with message.

Similiary are saved SMS includes numbers where are sent messages about lift failure.

- Programm start without PIN (when you have special unit issue with preprogrammed PIN – programm appropriate PIN).
- The index (1-8) after MASTER (TEST) name define order in which are dial the numbers. Feel free to save as much MASTERx (TESTx) as you need ( for example: MASTER1 only). **CAUTION! All must be written by Capitals ! The space must not be between name and index (MASTER1)! Phone numbers must be saved in international format (for example: +420123456789).**
- When order of the names is interrupted (for example: MASTER1, MASTER2,MASTER4) the unit progressively dial up the numbers until space (in example MASTER1 and MASTER2). Afterward hang up. The numbers saved after space are valid for back call (MASTER) and programming (TEST). The numbers saved after space – it means numbers which are not dial up – might be multiple (on SIM card can be saved more numbers under name MASTER4). It means that numbers which might be used for back call or programming are limited by SIM card capacity only!
- The unit search preprogrammed SMS up order. **On the SIM must not be saved any other SMS except programmed.** At first position must be saved SMS message „ BACK UP“ (when you use for setting GSM Lift SET the „BACK UP“ SMS message is saved automatically). Position 2 is SMS message – failure lift 1 and Position 3 is SMS message – failure lift 2.

## The SIM programming on mobile phone

- Insert SIM card to mobile phone .
- To the phone book on the SIM card save phone numbers where unit is calling during activation (in international format!) under names MASTER1, MASTER2,...
- When SMS messages are saved on the SIM – erase them.
- Save on the SIM card selected SMS with phone number where should be sent information about low credit.. **The message must be saved in list of SMS as 1.!** When SMS is not saved – it is not send.
- As second SMS saved message with phone number where should be sent message about failure of lift 1.
- As third SMS saved message with phone number where should be sent message about failure of lift 2.  
When SMS are not saved – it is not send.
- Switch off the mobile phone and take out the SIM card.

Note: during work with mobile progress up mobile guide.SMS messages (mentioned above) are mostly saved as unsend.

## Remote programming via SMS

It is describe in capture of remote control.

## PC programming

It is describe in guide of setting sw.

## Operation:

- Insert the SIM card. (SIM card holder release by pushing of yellow button).

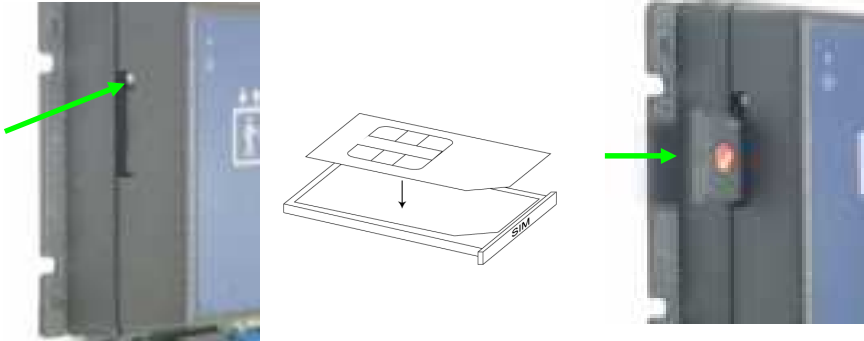

- Connect power supply.
- Green LED signalling GSM powering light up as same as yellow (red) LED powering at screw terminal. The red LED on ReMic modul light up as well.
- 3x shortly flash red LED GSM operation and start flashing in cca 2 second interval.
- LED GSM operation start flashing quickly – GSM net registration.
- LED GSM operation flashing again in 2 second interval – stand by mode – wait cca 30 seconds and unit is ready for operation.
- When programm the unit from PC. Connect the special cable and make setting.
- Push button (calls must not be blocked – via blocking inputs): The red LED GSM operation flashing quickly (dialing preprogrammed numbers). Progresively are dial up numbers saved as MASTERx (when call is not picked up the unit hang up and dial following number ).



In loudspeaker you can hear signals of GSM network (search called part, ringing tone etc...). The signalization screws I1 of appropriate ReMic modul are closed. After call picking up by called part is established connection to lift cabin. The signalization screws I1 are open and signalization screws I2 are closed. When button is pressed again the unit dial number in next order (next MASTER).

Adjust the loudness of ReMic modul on the basic unit (thin screw driver!). Set it carefully to avoid of acoustic short circuit.

- By hanging up on called part the connection is ended. The connection is also ended after time out 4 minutes.
- The same test will make at second ReMic modul.  
( when you use it for 2nd lift cabin)
- Make incoming call on the unit from selected MASTER number: your call will be picked up and established connection to lift cabin. By hanging up the connection is ended.
- Make incoming call on the unit from none MASTER number: your call will be refused.
- When is low credit – after connection must be sent SMS with info about low credit.
- Try sending SMS when lift is failure ( lift blocking – short circuit on input removed on time longer than 2 minutes).
- Try switching of relay contact for reset.
- Connect data inputs and make rest wiring which has not been done yet.

## Remote control and setting by SMS

The unit might be control and setting remotely by SMS. It might be done only from numbers saved on the SIM card as TEST1 to TEST8. The SMS from another numbers are accepted but erased.

**CAUTION! When you are erasing numbers remotely please note that min. 1 TEST number must stay on the SIM card. Otherwise you cant make any other remote setting..**

The SMS messages are always written by **CAPITALS**. The SMS are splited to 3 groups.

### Order SMS

It is SMS makes some feature. It has not any parametr only identificator.

### STAT, RES1, RES2, RST

#### Setting SMS

It is SMS makes settings of the unit. It enables make changes in setting as same as erasing of numbers (MASTER and TEST) saved on the SIM card. It contains 2 parts seperated by comma:

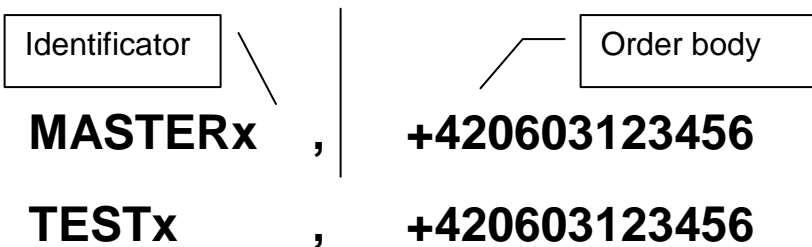

#### System SMS

It is global SMS for control of GSM modul TC 35i.

Those SMS we recommend to be used by qualified person only!



The system SMS contains 2 parts:

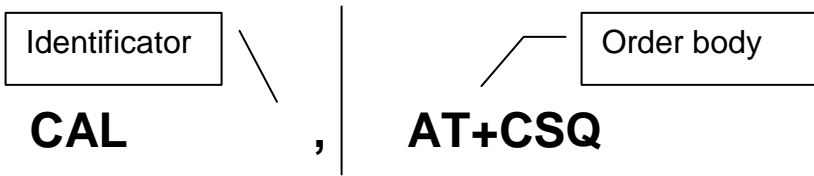

In Order table below we mention some examples of orders.

**The full table of orders is available on the base of your demand !**

## ORDER TABLE

ιδεν τιφ.	παρ.	ορδερ βοδ ψ	εξαμπλε	δεσχριπτιον	ΣΜΣ ρεπλψ
ΜΑΣ ΤΕΡ	1 το 8	, πηονε νυμβερ ρσ) <sup>1</sup>	ΜΑΣΤΕΡ1,+42060 212311	αδδ ορ χηανγε πη ονε νυμβερ	∇ΟΚ∇
ΜΑΣ ΤΕΡ	1 το 8	,	ΜΑΣΤΕΡ2,	ερασιγγ της πηονε νυμβερ	∇ΟΚ∇
ΤΕΣΤ	1 το 8	, πηονε νυμβερ ρσ) <sup>1</sup>	ΤΕΣΤ1,+42060212 3111	αδδ ορ χηανγε πη ονε νυμβερ	∇ΟΚ∇
ΤΕΣΤ	1 το 8	,	ΤΕΣΤ2,	ερασιγγ της πηονε νυμβερ	∇ΟΚ∇
ΣΤΑΤ			ΣΤΑΤ	στατυς οφ ιντυτς (ΠΟΡΤ)	∇ξξξξξ∇, ωηερε ξ ισ 0 ορ 1 υπ στατ υς οφ αππροπριατ ε ιντυτ (εξαμπλε : ωηεν ισ βλοχκινγ οφ βοτη λιφτς τη ε ΣΜΣ φορματ αιλλ βε: ∇ 11100∇
ΡΕΣ1			ΡΕΣ1	χλοσιγγ οφ ρελαψ χονταχτ 1 φορ 5 σεχονδς ( φορ εξαμπλε ΡΕΣΕΤ οφ της λιφτ )	∇ΟΚ1∇
ΡΕΣ2			ΡΕΣ2	χλοσιγγ οφ ρελαψ χονταχτ 2 φορ 5 σεχονδς ( φορ εξαμπλε ΡΕΣΕΤ οφ της λιφτ)	∇ΟΚ2∇
ΡΣΤ			ΡΣΤ	Υνιτ ρεσταρτ	∇ΡΕΣΤΑΡΤ∇
ΧΑΛ		, ΑΤΔ6031234 56;	ΧΑΛ,ΑΤΔ6031234 56;	της νιτ αφτερ ρε χειωινγ ΣΜΣ χαλ λ πρεπρογραμμεδ νυμβερ) <sup>2</sup>	∇ΟΚ∇ – χοννεχτι ον μαδε ∇ΝΟ ΧΑΡΡΙΕΡ∇ – υναχχεσαβλε ∇ΒΥΣΨ∇ – βυσψ
ΧΑΛ		, ΑΤΗ	ΧΑΛ,ΑΤΗ	ενδιγγ οφ χυρρεντ χαλλ	

ΧΑΛ	, AT+ΧΠΑΣ	ΧΑΛ,ΑΤ+ΧΠΑΣ	στατυσ οφ νυιτ	√+ΧΠΑΣ: 0√ – στανδ βψ √+ΧΠΑΣ: 3√ – ινχομινγ χαλλ ι σ χομινγ √+ΧΠΑΣ: 4√ – χοννεχτιον
ΧΑΛ	, AT+ΧΣΘ	ΧΑΛ,ΑΤ+ΧΣΘ	Υνιτ ΓΣΜ σιγναλ στρενγητ	√+ΧΣΘ: 17,99√ – φιρστ νυμβερ βεφ ορε χομια ισ σιγν αλ στρενγητ (μαξ 32), μιν. θαλυε φορ οπερα τιον ισ χχα 17
ΧΑΛ	, AT+ΧΑΧΜ?	ΧΑΛ,ΑΤ+ΧΑΧΜ?	χρεδιτ θαλυε ατ πρεπα δ χαρδ )3	√+ΧΑΧΜ: 01ΦΑ0 0√
ΧΑΛ	, AT+ΧΑΜΜ?	ΧΑΛ,ΑΤ+ΧΑΜΜ?	χρεδιτ μαξιμουμ) <sup>3</sup>	√+ΧΑΜΜ: 00ΦΦ4 Α√
ΧΑΛ	, AT+ΧΠΒΡ=π αρ.	ΧΑΛ,ΑΤ+ΧΠΒΡ=1	ΜΑΣΤΕΡ ορ ΤΕΣΤ νυμβερ ασσυρινγ ον ποσι τιον 1 το 8.	+ΧΠΒΡ: 1,√+4206 02123111√,145,√ ΜΑΣΤΕΡ1√
ΧΑΛ	, AT+ΧΧΛΚ=?	ΧΑΛ,ΑΤ+ΧΧΛΚ=?	Χλογκσ ιν τηε υνι τ	+ΧΧΛΚ: 00/01/01, 01:17:36 ) <sup>3</sup> χλογκσ αρε σταρ τινγ φρομ 1.1.00. αφτερ στα ρτ. Ιτ σηοωσ τηε τ ιμε οφ οπερατιον φρομ λαστ σταρτ (σηορτ φαϊλεδ αρ ε νοτ ρεγιστρατεδ)

## FAQ

### **LEDs are not lighting.**

Power supply fault. Verify power supply connection and polarity.

Does not happen quick flashing of „registration“ - red GSM LED.

The unit is not registered to GSM net:

- Fault SIM card (or bad inserted)
- Old 5V SIM card (unit support 3V and less)
- Set registration with PIN
- Bad GSM signal

Nothing happen after button pressing.

On the SIM card are not saved MASTERx numbers.

Appropriate blocking input is short circuit.

In connection you hear interferences.

The power supply is AC or not filtrated enough.

The GSM signal penetrate to voice channel (via. Instalation).

Some wire (except powering) is grounded.

In connection you can hear acoustic shock (whistling, ECHO etc..)

Too big amplification in whole system (micro of called part phone – loudspeaker in lift cabin – acoustic parametres of lift cabin – micro in lift cabin – handset). You have to decrease of ReMic loudness.

Bad loudness from lift cabin.

Faulty installation of microphone or bad setting of micro amplification.(via. Instalation).

# The basic connection for 2 lift cabin, power supply 12V from lift battery

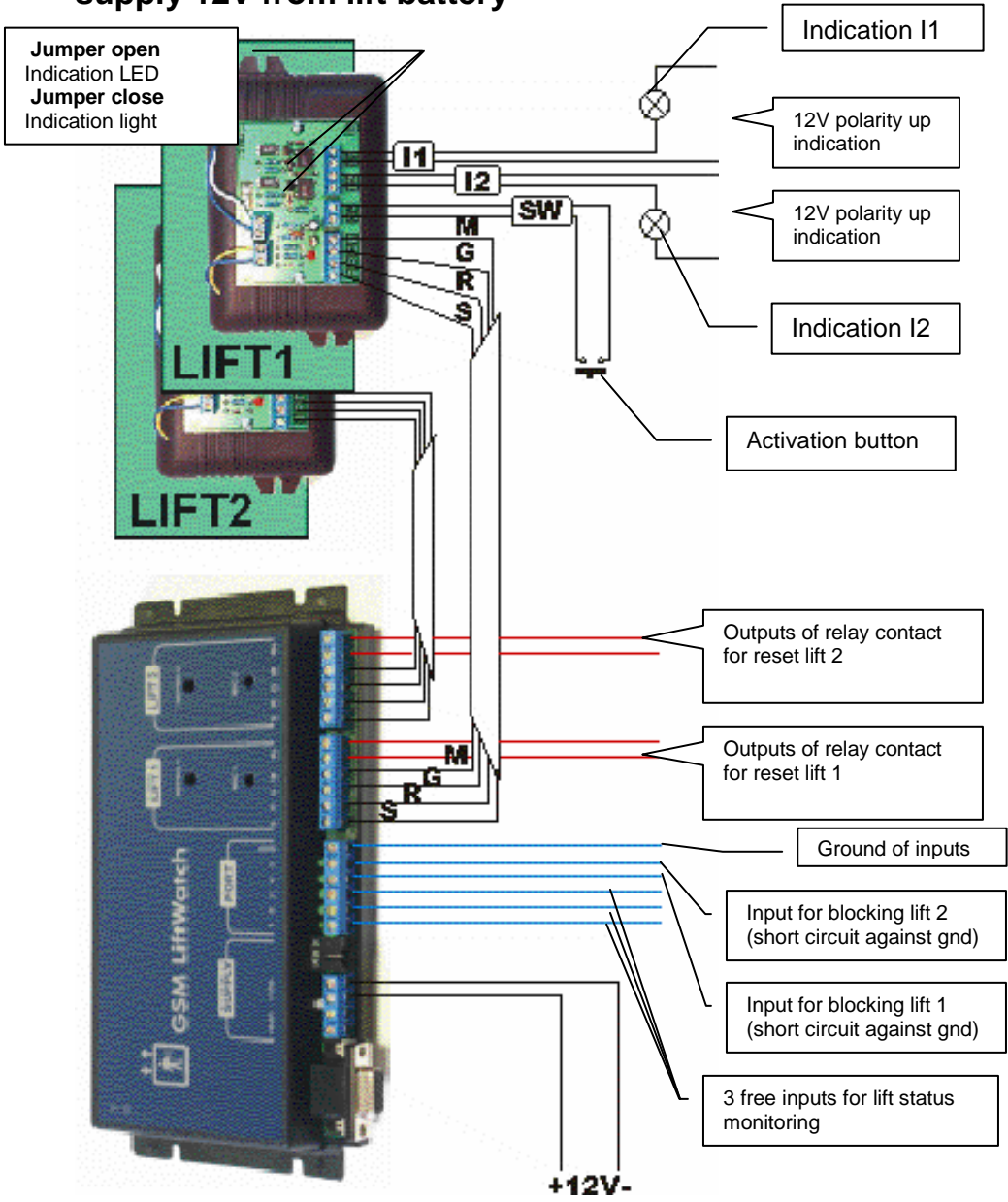

# Connection for 2 lift cabin, powering from main adapter

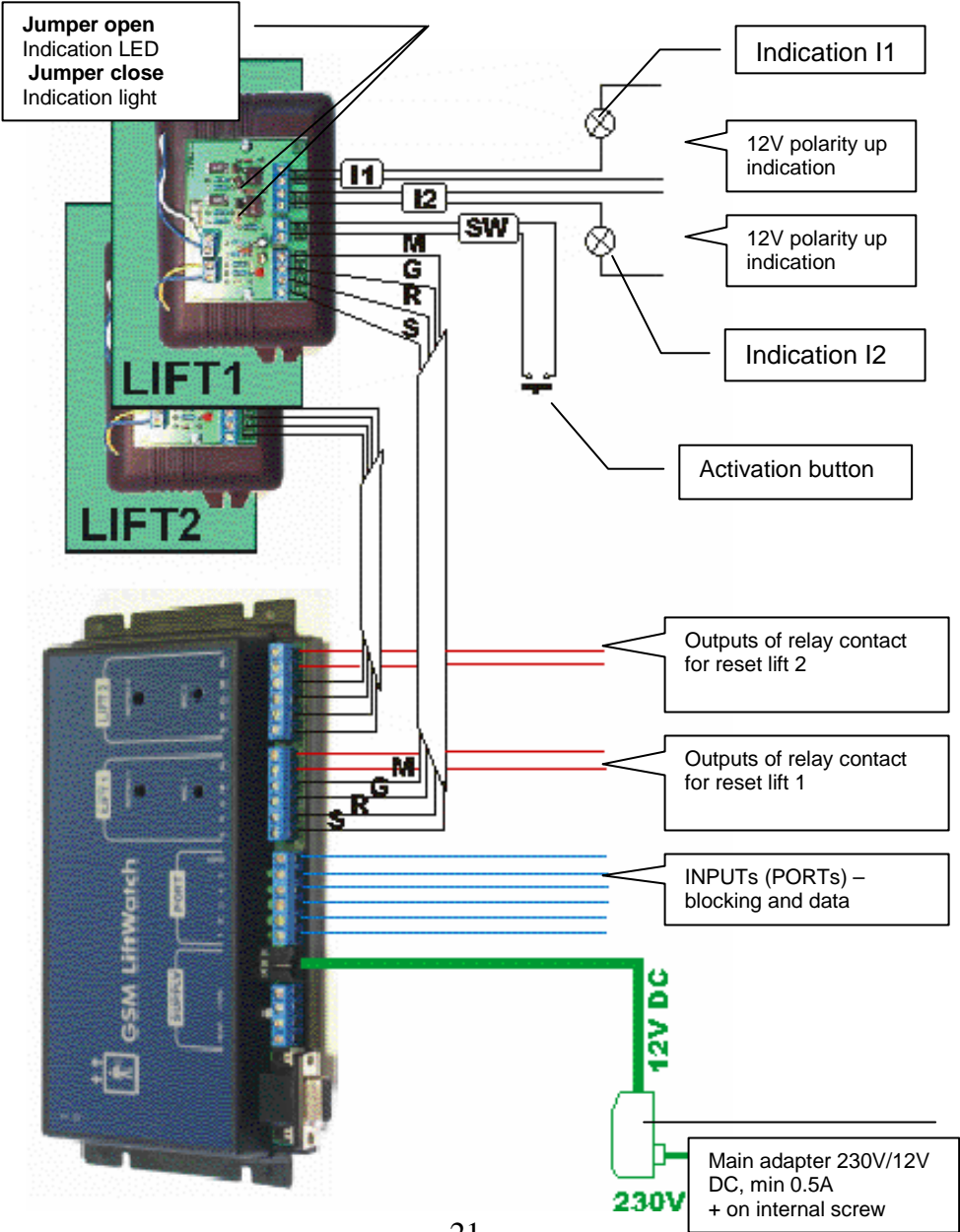

# Connection for 2 lift cabin, powering from charging main adapter, backup acumulator

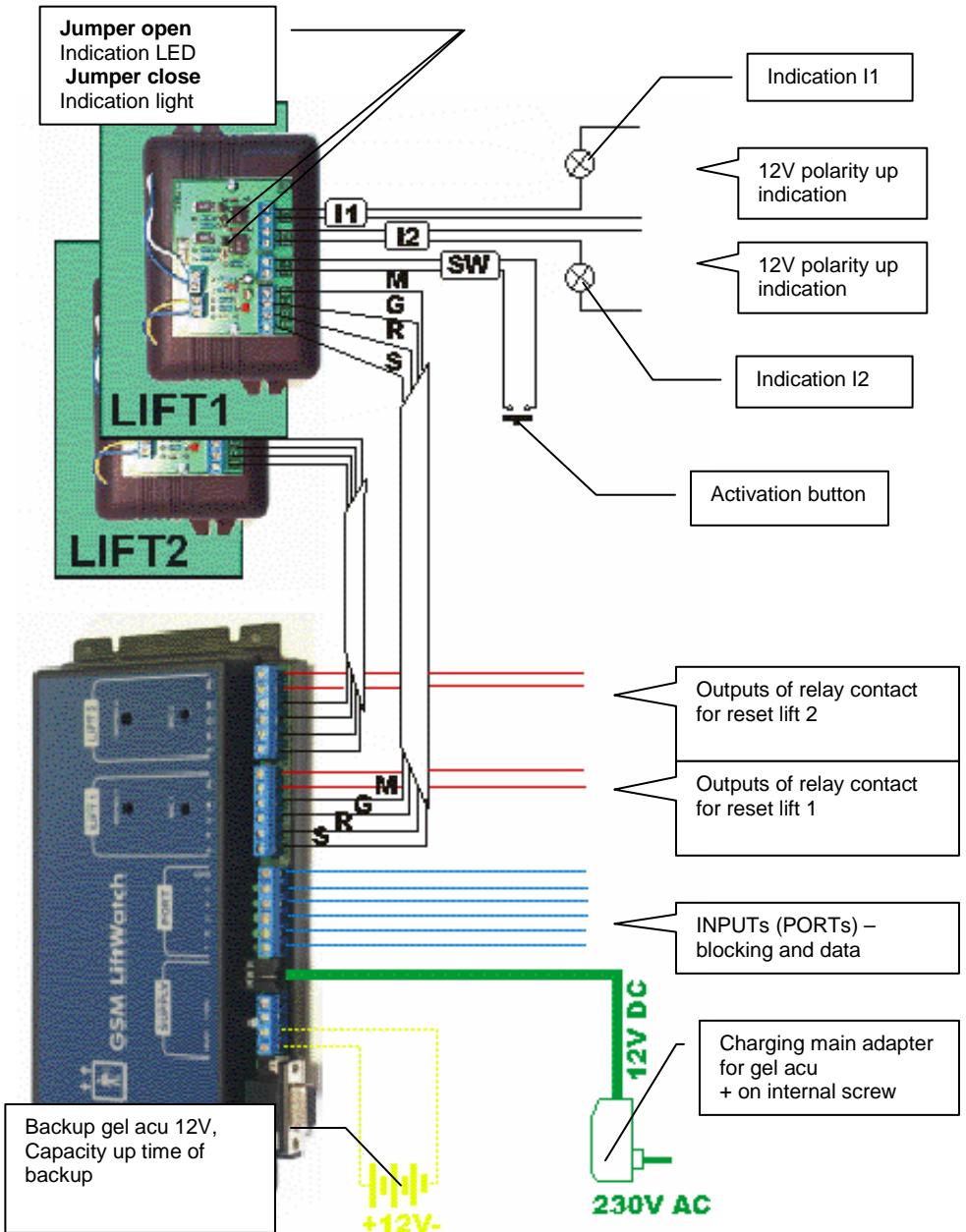

# Basic connection for 1 lift cabin, powering from 12V lift battery

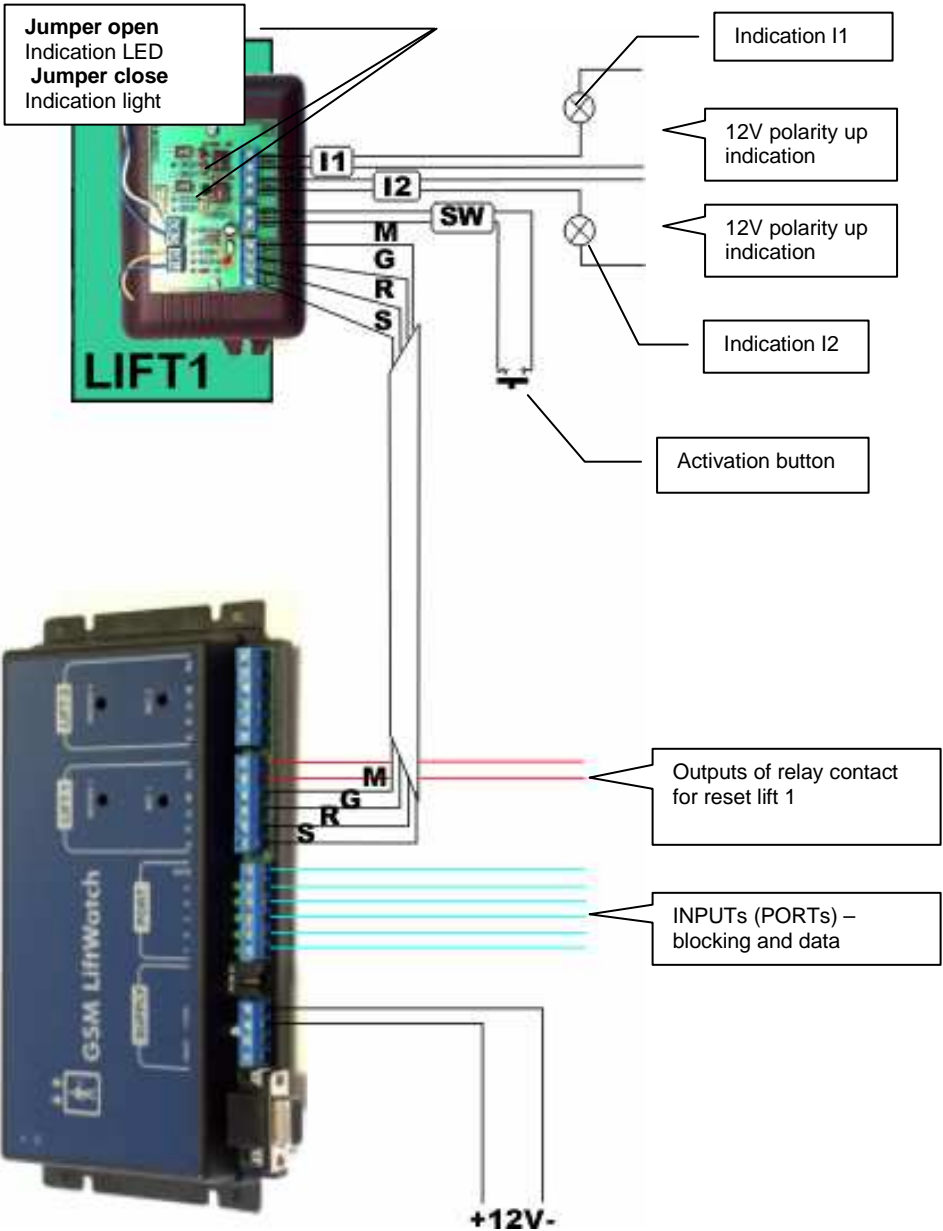



# Connection of ReMic modul indication when only 1 indicator is used (connection established + communication)

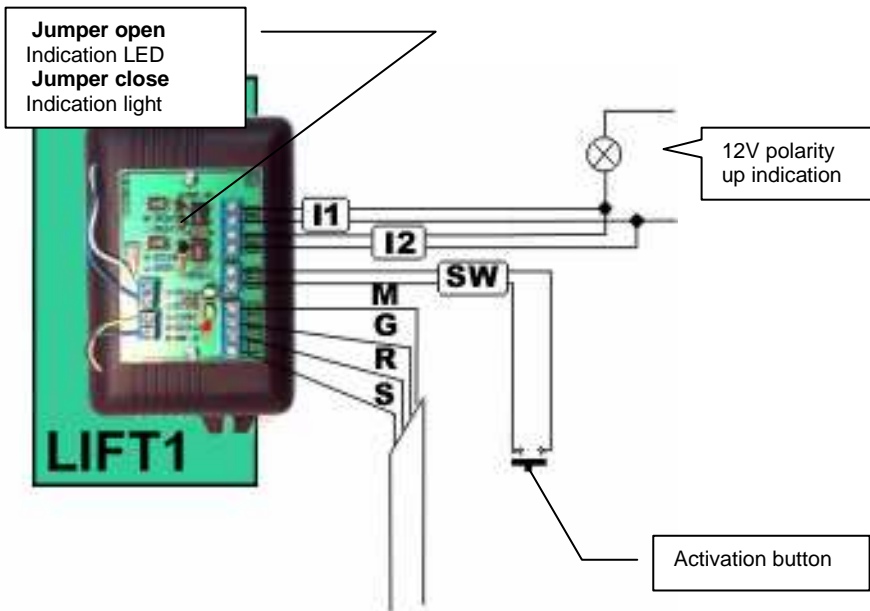

The connection of new REMIC is the same as previous model of REMIC

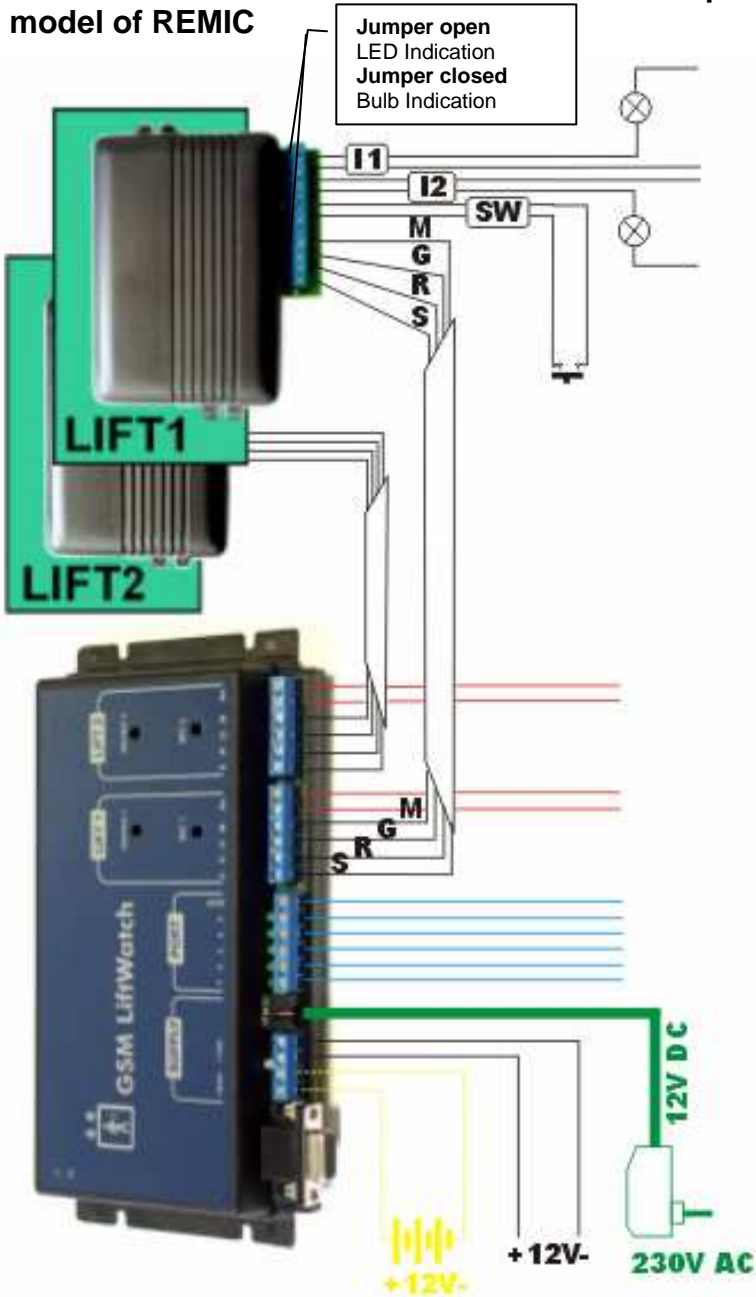

**Example of connection – activation by galvanically isolated screws of 12V switch at new ReMic – connection to bell or Alarm.**

